

SPARX

CLASSIC MOTORCYCLE
ELECTRICAL PRODUCTS

ELECTRONIC IGNITION KIT

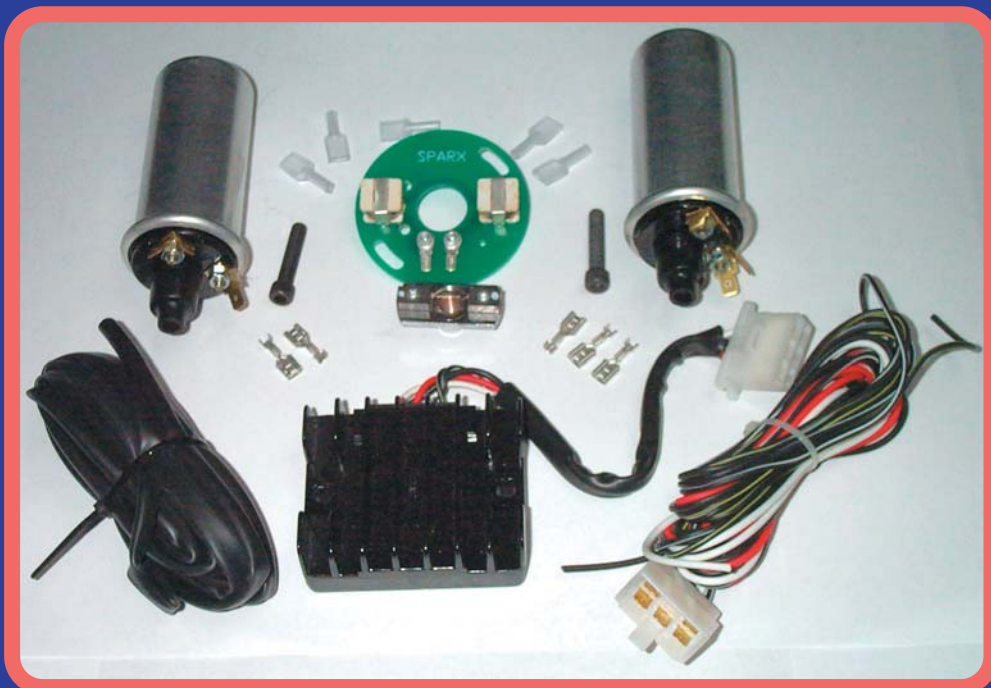

WIRING DIAGRAM Negative Earth

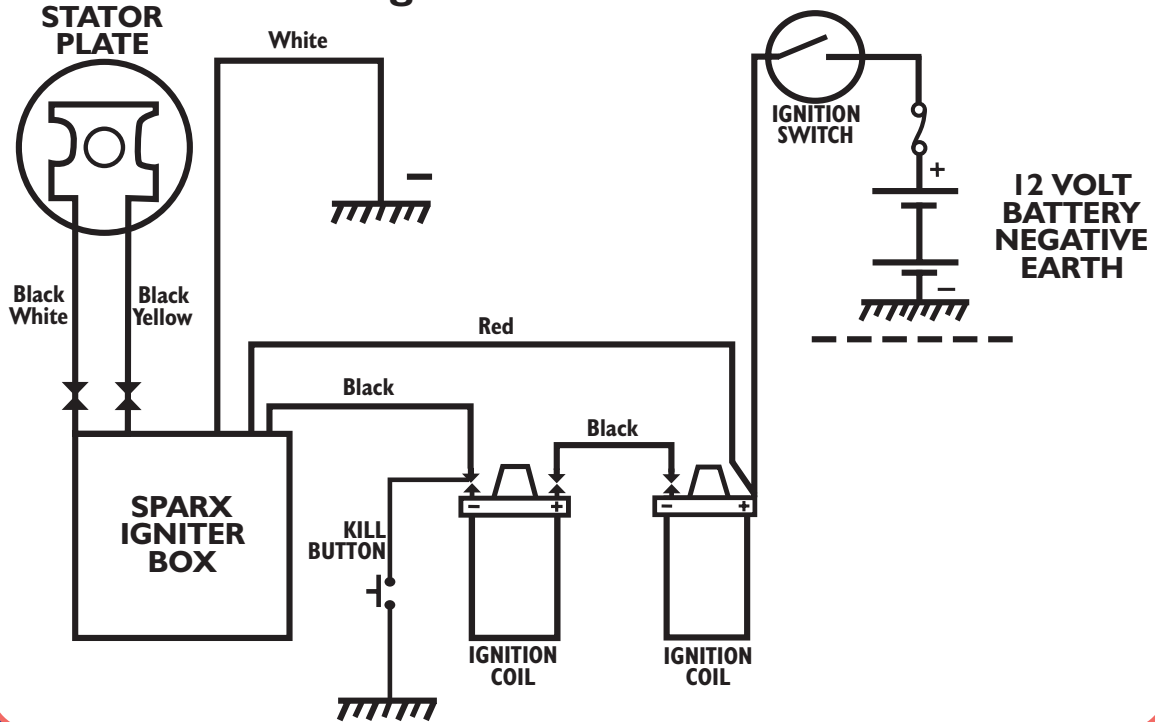

WIRING DIAGRAM Positive Ground

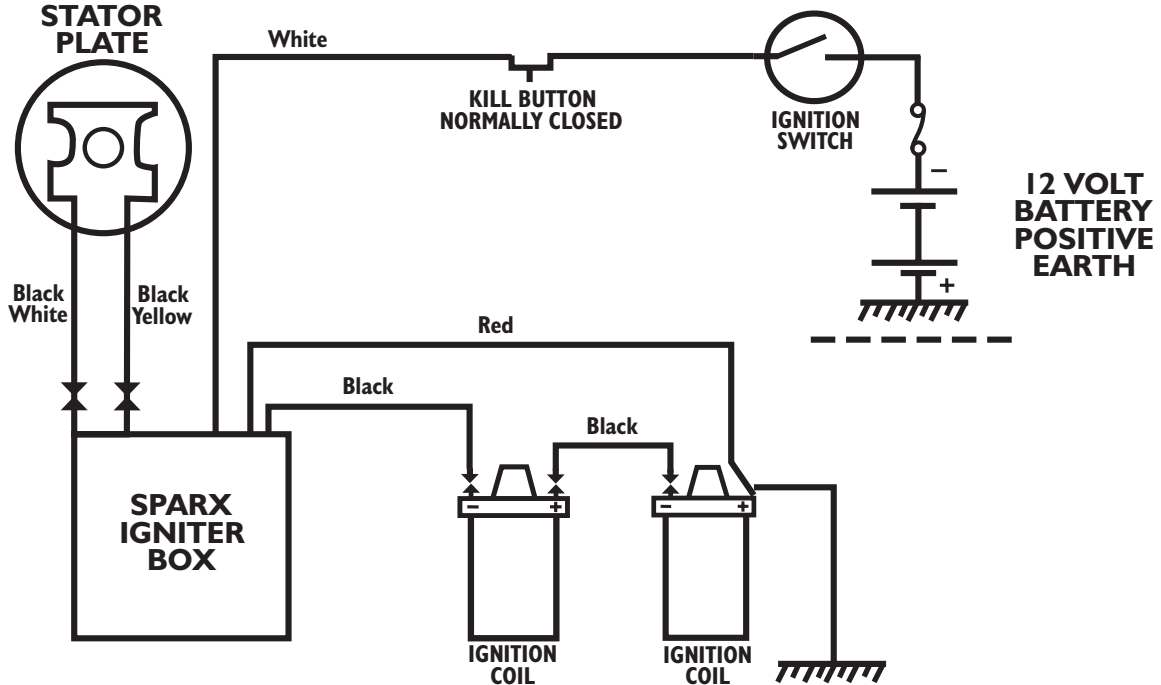

KILL BUTTONS

In addition to the optional kill button illustrated on the positive ground wiring diagram above you can use a grounding kill button attached to the black/yellow wire on either a positive or negative ground system. **NEVER** put a grounding kill button on the black wire on a positive ground system



1 MOUNT THE IGNITER BOX IN A SUITABLE PLACE.



2 PLACE THE ROTOR INTO THE CAMSHAFT AND INSERT ALLEN BOLT AND LEAVE LOOSE SO YOU CAN ADJUST THE ROTOR POSITION.



3 MOUNT THE STATOR PLATE SO THE PILLAR BOLTS ARE IN THE CENTRE OF THE ADJUSTMENT SLOTS, THIS WILL AID WITH TIMING LATER ON.



4 SET THE CRANK SHAFT IN THE STATIC B.T.D.C POSITION. THIS WILL VARY WITH DIFFERENT MODELS OF MOTORCYCLE SEE YOUR MANUAL FOR SPEC.



5 IF THE CAMSHAFT TURNS CLOCKWISE TURN THE ROTOR UNTIL YOU SEE SCREW IN THE BOTTOM HOLE THEN TIGHTEN THE ALLEN BOLT. THIS WILL GIVE YOU A GOOD STATIC TIME TO STROBE LATER.



6 IF THE CAMSHAFT TURNS ANTI-CLOCKWISE TURN THE ROTOR UNTIL YOU SEE THE SCREW IN THE TOP HOLE THEN TIGHTEN THE ALLEN BOLT. THIS WILL GIVE YOU A GOOD STATIC TIME TO STROBE LATER.



7 CONNECT THE BLOCK CONNECTOR TO THE IGNITER BOX AND WIRE UP AS THE DIAGRAM SPECIFIES FOR YOUR MOTORCYCLE (+ OR - EARTH ETC).



8 ROUTE THE STATOR PLATE WIRES VIA THE SHORTEST ROUTE (AVOIDING AC WIRES FROM THE ALTERNATOR AS THIS CAN CAUSE INTERFERENCE) TO THE ENGINE AND CUT TO LENGTH. USE OUTER SHIELDING AS SUPPLIED AND CRIMP TO THE TERMINAL CONNECTORS (CONNECT BLACK & WHITE WIRE TO RIGHT HAND TERMINAL).



9 WHEN ROUTING THE STATOR PLATE WIRE TO THE ENGINE LEAVE A LITTLE J SHAPED LOOP IN THE WIRE CLOSE TO THE ENGINE AND LOOSELY CABLE TIE TO THE FRAME, THIS WILL STOP THE WIRE BREAKING DOWN UNDER VIBRATION ESPECIALLY ON NORTON ISOLASTIC FRAMED MODELS.



10 USING A STROBE LIGHT REV THE ENGINE TO 5000 RPM (THE IGNITIONS FULL ADVANCE SETTING 13 DEGREES) TURN THE STATOR PLATE ON ITS SLOTS UNTIL THE TIMING MARK ON THE ALTERNATOR ROTOR ALIGNS WITH THE POINTER ON THE CASE. (USING A WHITE MARKER LINE ON THE ROTOR TIMING MARK WILL HELP).

THE ENGINE SHOULD NOW BE FULLY TIMED AND READY TO GO. PLEASE READ THE SECTION ON BATTERY PERFORMANCE AND THE REST OF THE INSTRUCTION SHEET BEFORE USE AS SOMETIMES UNRELATED PROBLEMS CAN CAUSE IGNITION PROBLEMS.

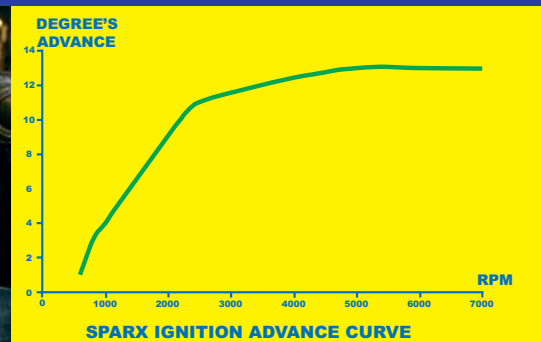
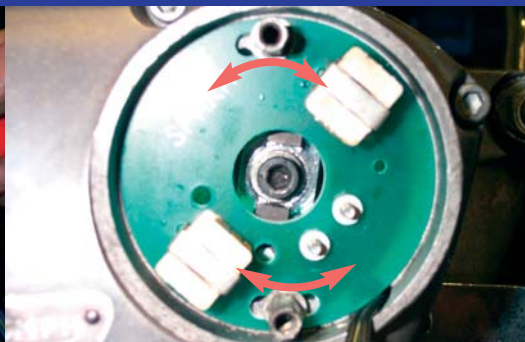

THE SPARX IGNITION KITS ADVANCE CURVE HAS BEEN DESIGNED TO ADVANCE FROM 600RPM STEADILY THROUGH TO 5000RPM FULL ADVANCE (13 DEGREES). IF PROBLEMS ARE EXPERIENCED PLEASE GO TO OUR WEBSITE -

www.sparxelectrical.com

LOOK AT THE TECHNICAL PAGE FOR THE IGNITION SYSTEMS, THIS GIVES SOME GOOD TECHNICAL ASSISTANCE FOR THE PROBLEMS THAT CAN OCCUR.

THANKYOU FOR PURCHASING YOUR SPARX ELECTRONIC IGNITION SYSTEM

PLEASE READ THE INSTRUCTIONS BEFORE FITTING

To fit the system requires a basic mechanical and electrical knowledge, if you are not familiar with these skills please allow a competent mechanic to install the kit as you may cause damage to the kit or your motorcycle if it is not fitted correctly.

Just because your motorcycle runs with a points system does not mean that it will run with a electronic system as the condition of the battery/coils/switches/HT leads and electrical connections etc can affect a electronic system where a points system will run unaffected, this is why we supply the coils and a fitting harness with the kit to minimise possible problems and eliminate unnecessary connections.

EARTHING, COILS & CHARGING SYSTEM

The Sparx system will run positive or negative earth (see the appropriate diagram) and with 6V or 12V coils, although we supply 6V coils as they aid starting and are better for use with performance motors. **CAUTION: DO NOT MOUNT THE COILS IN FOAM OR ANY TYPE OF INSULATION MATERIAL AS THIS CAN CAUSE OVERHEATING AND FAILURE.**

If you want to fit a double HT lead coil a 12 volt coil with 3-4.5 OHM resistance will be suitable.

The charging system of your motorcycle must be able to supply 11-14 volts while under load.

For motorcycles with halogen lamps/electric starters and other high usage equipment we recommend you use the Sparx 210 watt 3 phase charging kit for best charging performance (you should also fit 5000 OHM spark plug caps).

If you still use the old style Zener diode and plate rectifier system please check to confirm these parts are in good condition before using with the kit as the condition of the charging system can affect the performance of the ignition system.

BATTERY CONDITION

The battery must be in good condition and capable of holding a minimum of 11 volts with a 5 amp load, if a electric starter is fitted it must be capable of giving 5 amps on top of the load the starter needs.

A good basic test can be done on the motorcycle without expensive equipment by turning on the headlamp and brakelights then place a volt meter across the battery terminals, if it drops below 11 volts within a few minutes it is faulty (a good battery should sustain 12 volts for 10 minutes).

New batteries are not always good, sulphation and/or poor and broken connections in the battery can make it useless.

Modern batteries come 75% charged meaning you only have to charge it for a couple of hours against 10 or so hours for a older style battery, handy but no necessarily good because with a modern style battery if you do not trickle charge it within a few hours of adding the acid the plates will sulphate and it will ruin your new battery, also if you have a new battery and when you take off the vent pipe seal it doesn't "hiss" as it opens the vacuum seal it will probably be useless.

It pays to load test a new battery before you fit it to your motorcycle as it may save time later on when you can not find a fault and it turns out to be your nice new battery!

Switches also can be deceptive as when you test it with an OHMS meter it may read fine but when a load is added it can break down.

The Sparx kit has been designed to minimise the amount of connections in the circuit and these should be soldered when fitting for best results.

Follow the simple instructions and pictures and the kit should give you years of trouble free use.

If you do encounter problems there is some technical advice on our website

www.sparxelectrical.com